

Special Applications

Drain channel system MAXI 100 / 150 / 200

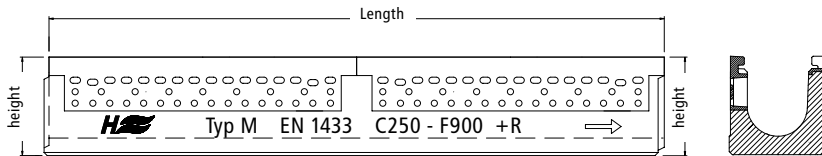

Installation example

MAXI 100 class C250 - F900

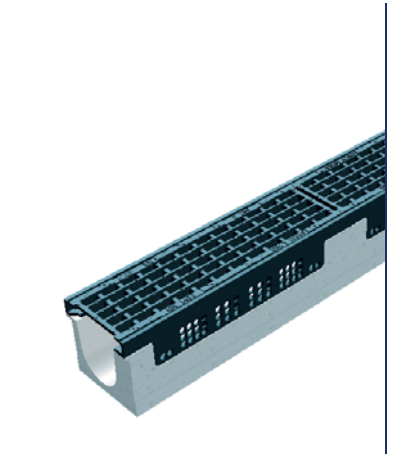
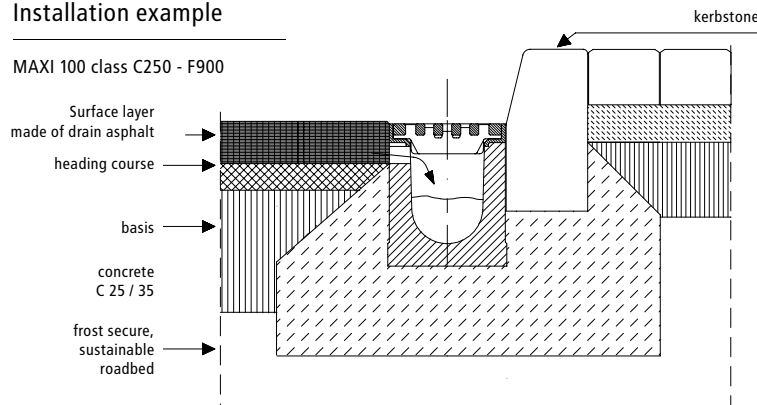

Top frame MAXI 150

For the later installation of the final surface layer.
The solution for the 2-phasing installation.

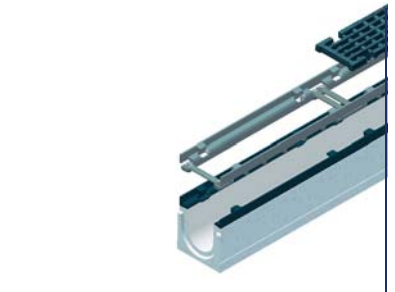
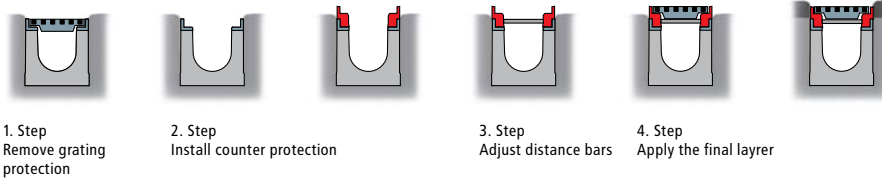

Cable channel system MAXI 150

- with inner separator
- no stumble danger
- loading class C 250 – F 900
- screwless patented fixing of the gratings
- secure anchored edge protection made of ductile iron
- channel made of fibre-reinforced concrete C35/45

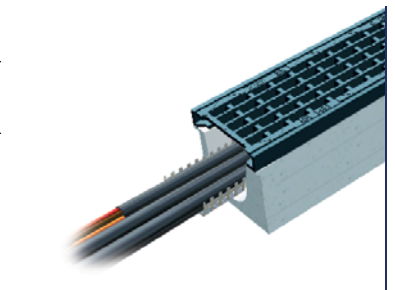
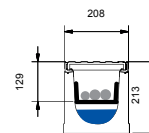
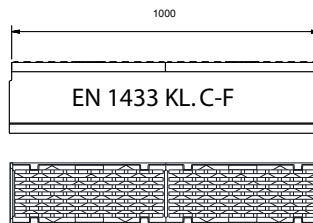

Slotted channel system MINI 100

Top with a sideways or central slot.
Optimal for inconspicuous drainage of paved areas and for facade drainage.

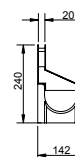
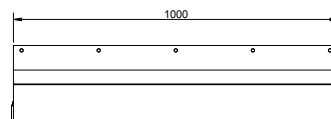

The slotted top is galvanised or made of stainless steel for the loading class B 125.

